

# TIMBER TO TIMBER – BACKER FREE

Page 1 of 4

FOR USE WITH PRODUCTS  
 MANUFACTURED BY:

**finnforest**  
 FinnFrame

The ITB is a revolutionary hanger that satisfies the demand for backer-block free timber to timber connectors in I-joist floors.

The ITB is stronger, safer, saves build time and dramatically reduces floor build costs. It features unique top and bottom flanges specially designed to resist rotation.

The ITB is the most popular backer-free hanger in the UK.

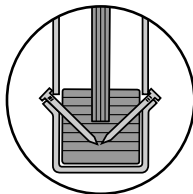

**PAN Nailing**

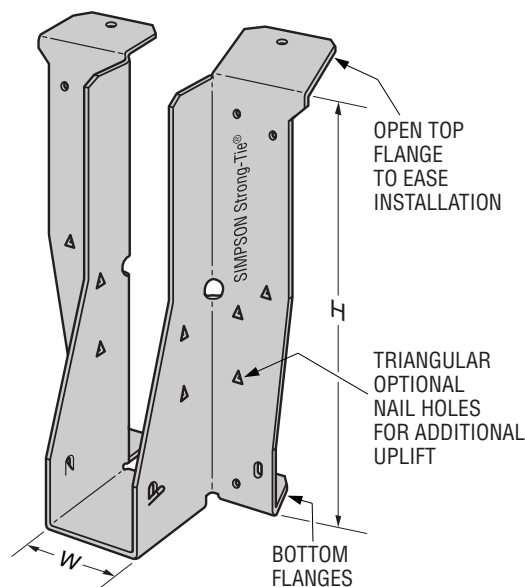

**ITB**

Patent No. GB 2400384

## FEATURES AND BENEFITS

- Eliminates the need for backer blocks when supported from an I-joist header.
- Can be used on I-joist or solid joist headers.
- Bottom flanges provide enhanced download capacity and quickly sets the hanger onto the header.
- Open top flange improves ease-of-installation.
- Obround holes in face to provide easier nailing access in tight locations.
- Positive Angle Nailing (PAN) of joist to speed installation and reduce the likelihood of splitting.
- Only one size of nail required – 3.75 x 30mm.
- Optional nail holes for additional download and uplift capacity.

**MATERIAL:** Mild Steel to BS EN 10142 DX51D + Z275

**FINISH:** Galvanised

01827 255 600  
[www.strongtie.co.uk](http://www.strongtie.co.uk)

T-UK-CSGFF1A 6/05

# TIMBER TO TIMBER – BACKER FREE

## ITB I-JOIST HANGERS - SAFE WORKING LOADS

Model No.	Dimensions (mm)		Installation	Fasteners		Safe Working Loads (kN)			
	Height	Width		Header	Joist	Long Term	Medium Term	Long Term Uplift	Short Term Uplift
ITB(H)/(W)	195 Min	40 Min	Standard I-Joist Header	12 - 3.75 x 30	2 - 3.75 x 30	4.60	5.30	0.79	1.00
	302 Max	90 Max							
ITB(H)/(W)	195 Min	40 Min	Enhanced* I-Joist Header	18 - 3.75 x 30	2 - 3.75 x 30	8.40	9.50	0.79	1.00
	302 Max	90 Max							
ITB(H)/(W)	195 Min	45 Min	Enhanced** Uplift	18 - 3.75 x 30	6 - 3.75 x 30	8.40	9.50	2.38	2.98
	302 Max	90 Max							
ITB(H)/(W)	195 Min	45 Min	C16 Header	18 - 3.75 x 30	2 - 3.75 x 30	8.40	9.50	0.79	1.00
	302 Max	90 Max							

1. 3.75 x 30 refers to a galvanised square twist nail.

2. Standard Installation SWLs refer to I-joist headers without backer blocks.

\* Enhanced Installation refers to I-joist headers with backer blocks installed. Backer blocks are to be installed in accordance with the manufacturers recommendations.

\*\* Enhanced Uplift refers to I-joist or solid joists with additional joist nails. For I-joist applications web stiffeners are required. Web stiffeners are to be installed in accordance with the manufacturers recommendations. Uplift values are based upon theoretical nail capacity and are substantiated by test.

## ITB HANGERS FOR TIMBER I-JOISTS

FJI Size	Model No.	Dimensions (mm)			Non Stock
		Height	Width	Bearing	
195-38	ITB195/40	195	40	51	*
195-45	ITB195/45	195	45	51	*
195-58	ITB195/60	195	60	51	*
195-38 (2 ply)	ITB195/78	195	78	51	*
195-89	ITB195/90	195	90	51	*
200-38	ITB200/40	200	40	51	*
200-45	ITB200/45	200	45	51	*
200-58	ITB200/60	200	60	51	*
200-38 (2 ply)	ITB200/78	200	78	51	*
200-89	ITB200/90	200	90	51	*
220-38	ITB220/40	220	40	51	
220-45	ITB220/45	220	45	51	
220-58	ITB220/60	220	60	51	
220-38 (2 ply)	ITB220/78	220	78	51	
220-89	ITB220/90	220	90	51	
235-38	ITB235/40	235	40	51	*
235-45	ITB235/45	235	45	51	*
235-58	ITB235/60	235	60	51	*
235-38 (2 ply)	ITB235/78	235	78	51	*
235-89	ITB235/90	235	90	51	*
240-38	ITB240/40	240	40	51	
240-45	ITB240/45	240	45	51	
240-58	ITB240/60	240	60	51	
240-38 (2 ply)	ITB240/78	240	78	51	
240-89	ITB240/90	240	90	51	
300-38	ITB302/40	302	40	51	
300-45	ITB302/45	302	45	51	
300-58	ITB302/60	302	60	51	
300-38 (2 ply)	ITB302/78	302	78	51	
300-89	ITB302/90	302	90	51	

01827 255 600  
www.strongtie.co.uk

**TIMBER TO TIMBER – BACKER FREE**

**STANDARD INSTALLATION DETAILS**

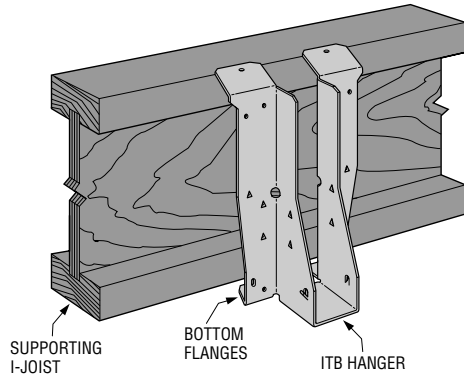

1

Position the ITB hanger onto the face of supporting I-joist, ensuring the bottom flanges are tight up against the underside of the bottom chord.

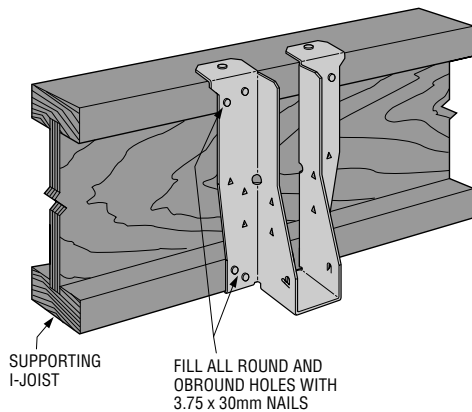

2

Fill all face round and obround holes with 3.75 x 30mm square twist nails.

Flatten the hangers open top flanges to the top chord of the supporting I-joist and fill round holes with 3.75 x 30mm nails.

Install 3.75 x 30mm nails into the holes within the bottom flanges.

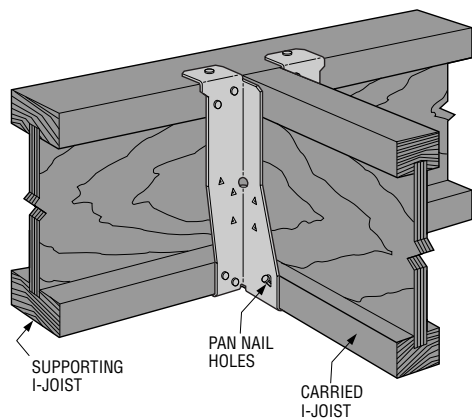

3

Sit the carried joist into the ITB Hanger and install 3.75 x 30mm nails through the angled PAN nail holes into the joist.

01827 255 600  
[www.strongtie.co.uk](http://www.strongtie.co.uk)

# TIMBER TO TIMBER – BACKER FREE

## ENHANCED INSTALLATION DETAILS

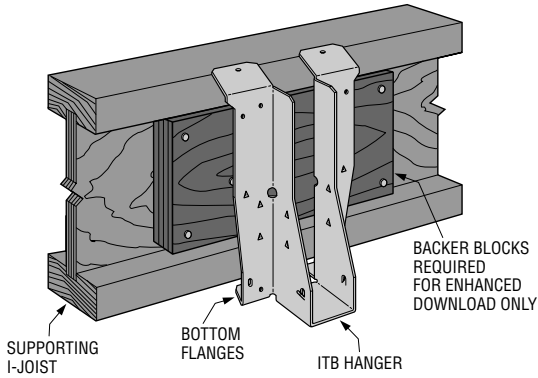

1

Fit backer blocks into the web of the I-joist header, ensuring they are installed in accordance with the manufacturers recommendations and are tight to the underside of the top chord.

Position the ITB hanger onto the face of supporting I-joist, ensuring the bottom flanges are tight up against the underside of the bottom chord.

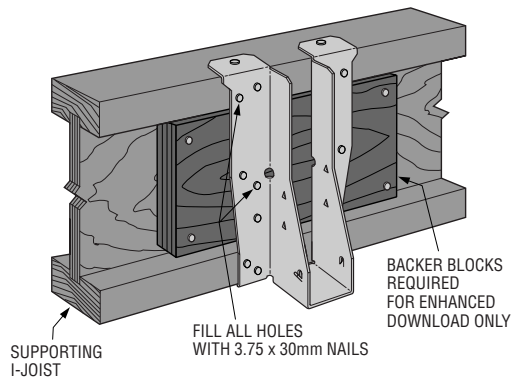

2

Fill all face holes with 3.75 x 30mm square twist nails. (14 in total)

Flatten the hangers open top flanges to the top chord of the supporting I-joist and fill round holes with 3.75 x 30mm nails.

Install 3.75 x 30mm nails into the holes within the bottom flanges.

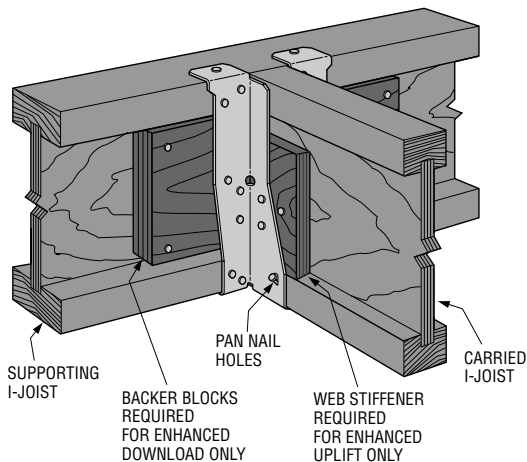

3

Sit the carried joist into the ITB Hanger and install 3.75 x 30mm nails through the angled PAN nail holes into the joist.

For Enhanced Uplift fill all joist triangular nail holes with 3.75x30mm nails.

When web stiffeners are required, ensure they are installed in accordance with manufacturers recommendations.

Refer to the current *Connectors for Timber and Masonry Construction* catalog for General Notes, Warranty Information and other important information, including Terms and Conditions of Sale, Building Code Evaluation listings and Corrosion Resistance.

Simpson Strong-Tie  
United Kingdom Office  
Winchester Road  
Cardinal Point  
Tamworth  
Staffordshire B78 3HG  
FAX: 01827 255 616

**01827 255 600**  
**www.strongtie.co.uk**